

Features

- 2:1 Input Range
- Operating Temperature Range: -40~105°C
- Approved to cURus, FCC, UKCA, CE, RoHS & REACH
- Safety Standards to IEC/UL/EN62368-1 & EC/EN/ANSI/AAMI ES 60601-1
- Efficiency up to 89%
- EMC Class A & B
- Single & Dual output 4.5~75V DC
- OCP, OTP, OVP SCP & UVP



Ideal Power's 43MOP10-xyz(W) 10W Series DIP DC/DC Converters are certified to cURus, UKCA, CE, FCC, CB, RoHS, REACH & IEC/EN/ANSI/AAMI ES 60601-1, IEC/EN/UL 62368-1 Standards and comply with the relevant Efficiency Regulations. These are primarily used in ITE, Video & Audio, Medical Industries and customised solutions are available upon request.

Part Number Structure

43MOP10	-	48	S	05	W	A	-	P	T
Series Name		Input Voltage (VDC)	Output Quantity	Output Voltage (VDC)	Input Range	Pin Connection Options		Remote On/Off Options	Trim Options
		05: 4.5 ~ 9 12: 9 ~ 18 24: 18 ~ 36 48: 36 ~ 75	S: Single	3P3: 3.3 05: 05 12: 12 15: 15 24: 24	<input type="checkbox"/> : 2:1	A: A type (Standard) B: B type		<input type="checkbox"/> : No pin P: Remote On/Off (Only for B type Pin Connection)	<input type="checkbox"/> : No Trim T: Trim (Only for B type Pin Connection)
			D: Dual	05: 05 12: +12 15: +15					
		24: 9 ~ 36 48: 18 ~ 75	S: Single	3P3: 3.3 05: 05 12: 12 15: 15 24: 24	W: 4:1	A: A type (Standard) B: B type		<input type="checkbox"/> : No pin P: Remote On/Off (Only for B type Pin Connection)	<input type="checkbox"/> : No Trim T: Trim (Only for B type Pin Connection)
			D: Dual	05: 05 12: +12 15: +15					

Models

Model Number	Input Range V DC	Output Voltage V DC	Output current @Full Load A	Input Current @ No Load A	Efficiency %	Maximum Capacitor Load μF
43MOP10-05S3P3A/B	4.5 ~9	3.3	2500	10	80	3000
43MOP10-05S05A/B	4.5 ~9	5	2000	10	84	2500
43MOP10-05S12A/B	4.5 ~9	12	830	20	86.5	430
43MOP10-05S15A/B	4.5 ~9	15	670	20	87	350
43MOP10-05S24A/B	4.5 ~9	24	416	20	85.5	125
43MOP10-05D05A/B	4.5 ~9	±5	±1000	25	83	± 1440
43MOP10-05D12A/B	4.5 ~9	±12	±416	25	85.5	± 250
43MOP10-05D15A/B	4.5 ~9	±15	±333	25	86.5	± 180
43MOP10-12S3P3A/B	9 ~ 18	3.3	2500	10	83	3000
43MOP10-12S05A/B	9 ~ 18	5	2000	10	85.5	2500
43MOP10-12S12A/B	9 ~ 18	12	830	10	88	430
43MOP10-12S15A/B	9 ~ 18	15	670	10	89	350
43MOP10-12S24A/B	9 ~ 18	24	416	10	89	125
43MOP10-12D05A/B	9 ~ 18	±5	±1000	10	84	± 1440
43MOP10-12D12A/B	9 ~ 18	±12	±416	10	89	± 250
43MOP10-12D15A/B	9 ~ 18	±15	±333	10	88	± 180
43MOP10-24S3P3A/B	18 ~ 36	3.3	2500	6	83	3000
43MOP10-24S05A/B	18 ~ 36	5	2000	6	86.5	2500
43MOP10-24S12A/B	18 ~ 36	12	830	6	89	430
43MOP10-24S15A/B	18 ~ 36	15	670	6	89	350
43MOP10-24S24A/B	18 ~ 36	24	416	6	89	125
43MOP10-24D05A/B	18 ~ 36	±5	±1000	6	85	± 1440
43MOP10-24D12A/B	18 ~ 36	±12	±416	6	89	± 250
43MOP10-24D15A/B	18 ~ 36	±15	±333	6	88	± 180
43MOP10-48S3P3A/B	36 ~ 75	3.3	2500	4	82.5	3000
43MOP10-48S05A/B	36 ~ 75	5	2000	4	86.5	2500
43MOP10-48S12A/B	36 ~ 75	12	830	4	89	430
43MOP10-48S15A/B	36 ~ 75	15	670	4	89	350
43MOP10-48S24A/B	36 ~ 75	24	416	4	88.5	125
43MOP10-48D05A/B	36 ~ 75	±5	±1000	4	85	± 1440
43MOP10-48D12A/B	36 ~ 75	±12	±416	4	88	± 250
43MOP10-48D15A/B	36 ~ 75	±15	±333	4	88	± 180
43MOP10-24S3P3WA/B	9 ~ 36	3.3	2500	6	83	3000
43MOP10-24S05WA/B	9 ~ 36	5	2000	6	86.5	2500
43MOP10-24S12WA/B	9 ~ 36	12	830	6	89	430
43MOP10-24S15WA/B	9 ~ 36	15	670	6	89	350
43MOP10-24S24WA/B	9 ~ 36	24	416	6	89	125
43MOP10-24D05WA/B	9 ~ 36	±5	±1000	6	85	± 1440
43MOP10-24D12WA/B	9 ~ 36	±12	±416	6	89	± 250
43MOP10-24D15WA/B	9 ~ 36	±15	±333	6	88	± 180
43MOP10-48S3P3WA/B	18 ~ 75	3.3	2500	4	82.5	3000
43MOP10-48S05WA/B	18 ~ 75	5	2000	4	86.5	2500
43MOP10-48S12WA/B	18 ~ 75	12	830	4	89	430
43MOP10-48S15WA/B	18 ~ 75	15	670	4	89	350
43MOP10-48S24WA/B	18 ~ 75	24	416	4	88.5	125
43MOP10-48D05WA/B	18 ~ 75	±5	±1000	4	85	± 1440
43MOP10-48D12WA/B	18 ~ 75	±12	±416	4	88	± 250
43MOP10-48D15WA/B	18 ~ 75	±15	±333	4	88	±180

Input Specifications

Parameter	Conditions	Min	Typ	Max	Unit	
Operating input voltage range	2:1	5Vin(nom)	4.5	5	9	VDC
		12Vin(nom)	9	12	18	
		24Vin(nom)	18	24	36	
		48Vin(nom)	36	48	75	
	(W) 4:1	24Vin(nom)	9	24	36	
		48Vin(nom)	18	48	75	
Startup voltage	2:1	5Vin(nom)	--	--	4.5	VDC
		12Vin(nom)	--	--	9	
		24Vin(nom)	--	--	18	
		48Vin(nom)	--	--	36	
	(W) 4:1	24Vin(nom)	--	--	9	
		48Vin(nom)	--	--	18	
Shutdown voltage	2:1	5Vin(nom)	3	4	4.4	VDC
		12Vin(nom)	7	8	8.8	
		24Vin(nom)	15	16	17.5	
		48Vin(nom)	31.5	33	34.5	
	(W) 4:1	24Vin(nom)	7	8	8.8	
		48Vin(nom)	15	16	17.5	
Startup time	Constant resistive load	Power up	--	30	ms	
		Remote ON/OFF	--	30		
Input surge voltage	3 second, max.	5Vin(nom)	--	--	16	VDC
		12Vin(nom)	--	--	25	
		24Vin(nom)	--	--	50	
		48Vin(nom)	--	--	100	
	3 second, max.	24Vin(nom)	--	--	50	
		48Vin(nom)	--	--	100	
Input filter			Pi type			
Remote ON/OFF (Only for B-type Pin connection option)	Referred to - Vin pin	DC-DC ON	Open or 0 ~ 1.2VDC			
		DC_DC OFF	2.2 ~ 12VDC			
		Input current of CTRL pin	-0.5	--	1	mA
Remote off input current	--	2.5	--			

Output Specifications

Parameter	Conditions		Min	Typ	Max	Unit
Voltage accuracy			-1.0	--	+1.0	
Line regulation	Low Line to High Line at Full Load	Single	-0.2	--	+0.2	
		Dual	-0.5	--	+0.5	
Load regulation	No Load to Full Load	Single	-0.2	--	+0.2	
		Dual	-1.0	--	+1.0	%
Cross regulation	Asymmetrical load 25%/100% FL	Dual	-5.0	--	+5.0	
Voltage adjustability	Single output	3.3Vout, 5Vout, 12Vout	-10	--	+10	
		15Vout, 24Vout	-10	--	+20	
	Dual Output	±5Vout, ±12Vout, ±15Vout	-10	--	+10	
Ripple and noise	Measured by 20MHz bandwidth					
	With a 10µF/25V X7R MLCC	3.3Vout, 5Vout	--	30	--	mVp-p
		12Vout, 15Vout	--	40	--	
With a 4.7µF/50V X7R MLCC	24Vout	--	50	--		
Temperature coefficient			-0.02		+0.02	%/°C
Transient response recovery time	25% load step change		--	250	--	µs
Over voltage protection	Single	3.3Vout	3.7	--	5	VDC
		5Vout	5.6	--	7	
		12Vout	13.5	--	16	
		15Vout	18.3	--	22	
		24Vout	29.1	--	34.5	
	Dual	5Vout	5.6	--	7	
		12Vout	13.5	--	18.2	
Overload protection	% of Iout rated; Hiccup mode		--	150	--	%
Short circuit protection			Continuous, automatic recovery			

General Specifications

Parameter	Conditions		Min	Typ	Max	Unit
Isolation voltage	1 minute	Input to Output	3000	--	--	V AC
	Reinforced insulation for 250VAC working voltage					
Isolation resistance	500V DC		10	--	--	GΩ
Isolation capacitance			--	12	17	pF
Leakage current	240V AC, 60Hz		--	--	2	µA
Switching frequency			270	300	330	kHz
Clearance/Creepage			6.6	--	--	mm
Safety approvals	EC/ EN/ ANSI/AAMI ES 60601-1 IEC/ EN/ UL 62368-1					UL:E360199 UL:E193009 CB:UL(Demko)
Case material			Non-conductive black plastic			
Base material			Non-conductive black plastic			
Potting material			Silicone (UL94 V-0)			
Weight			14g (0.48oz)			
MTBF	MIL-HDBK-217F, Full Load		3.849 x 10 ⁶ hrs			

Environmental Specifications

Parameter	Conditions	Min	Typ	Max	Unit
Operating ambient temperature	With derating	-40	--	+77	°C
	Without derating	+77	--	+105	
Maximum case temperature		--	--	105	°C
Storage temperature range		-55	--	+125	°C
Operating altitude		--	--	5000	m
Thermal impedance		--	18	--	°C/W
Thermal Shock					MIL-STD-810F
Vibration					MIL-STD-810F
Relative humidity					5% to 95% RH

EMC Specifications

Parameter	Conditions	Level	
EMI	EN55011, EN55032, EN60601-1-2 and FCC Part 18 / 15	Class A Class B	
	Without external filter. With external filter.		
EMS	EN55024 and EN60601-1-2		
ESD	EN61000-4-2 Air ± 15kV and Contact ± 8kV	Perf. Criteria A	
Radiated immunity	EN61000-4-3 10 V/m	Perf. Criteria A	
Fast transient	EN61000-4-4 ± 2kV	Perf. Criteria A	
	43MOP10-05□□□		With an aluminum electrolytic capacitor (Nippon Chemi-con KY series, 1000µF/25V). and a reverse diode (Vishay V10P45) in parallel.
	43MOP10-12□□□□		With an aluminum electrolytic capacitor (Nippon Chemi-con KY series, 470µF/50V).
	43MOP10-24□□□□		With an aluminum electrolytic capacitor (Nippon Chemi-con KY series, 330µF/100V).
	43MOP10-48□□□□		With an aluminum electrolytic capacitor (Nippon Chemi-con KY series, 330µF/100V).
Surge	EN61000-4-5 ± 1kV	Perf. Criteria A	
	43MOP10-05□□□		With an aluminum electrolytic capacitor (Nippon Chemi-con KY series, 1000µF/25V). and a reverse diode(Vishay V10P45) in parallel.
	43MOP10-12□□□		With an aluminum electrolytic capacitor (Nippon Chemi-con KY series, 470µF/50V).
	43MOP10-24□□□□		With an aluminum electrolytic capacitor (Nippon Chemi-con KY series, 330µF/100V).
	43MOP10-48□□□□		With an aluminum electrolytic capacitor (Nippon Chemi-con KY series, 330µF/100V).
Conducted immunity	EN61000-4-6 10 Vr.m.s	Perf. Criteria A	
Power frequency magnetic field	EN61000-4-8 100A/m continuous, 1000A/m 1 second	Perf. Criteria A	

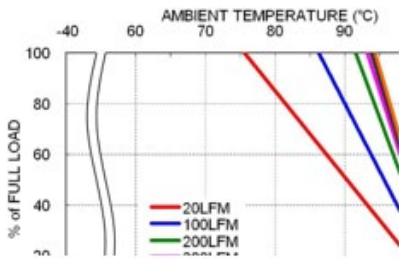
Characteristic Curve

43MOP10-48S05WA Derating Curve

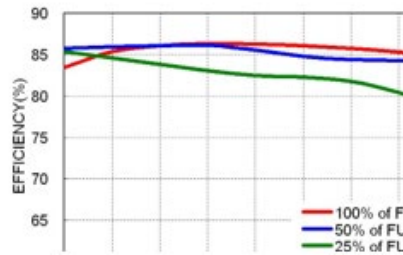

43MOP10-48S05WA Efficiency vs. Input Voltage

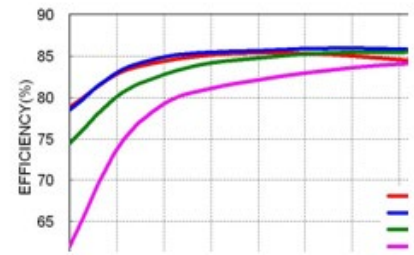

43MOP10-48S05WA Efficiency vs. Output Load

Fuse Considerations

This power module is not internally fused. An input line fuse must always be used.

This encapsulated power module can be used in a wide variety of applications, ranging from simple stand-alone operation to an integrated part of sophisticated power architecture.

To maximum flexibility, internal fusing is not included; however, to achieve maximum safety and system protection, always use an input line fuse.

The input line fuse suggest as below :

Model	Fuse Rating (A)	Fuse Type
43MOP10-05S□□、43MOP10-05D□□	5	Slow-Blow
43MOP10-12S□□、43MOP10-12D□□	2	Slow-Blow
43MOP10-24S□□、43MOP10-24D□□	1	Slow-Blow
43MOP10-48S□□、43MOP10-48D□□	0.5	Slow-Blow
Model	Fuse Rating (A)	Fuse Type
43MOP10-24S□□W、43MOP10-24D□□W	2	Slow-Blow
43MOP10-48S□□W、43MOP10-48D□□W	1	Slow-Blow

The table based on the information provided in this data sheet on inrush energy and maximum DC input current at low Vin.

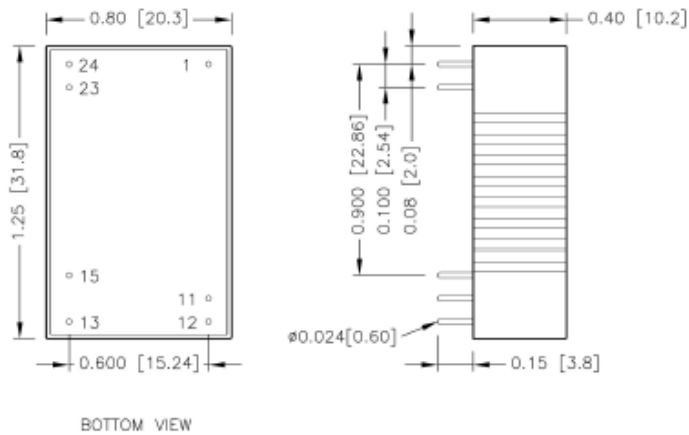
Mechanical Drawing
A TYPE

1. All dimensions in inch [mm]
2. Tolerance :x.xx±0.02 [x.x±0.5]
x.xxx±0.01 [x.xx±0.25]
3. Pin dimension tolerance ±0.004[0.10]

Pin Connection

Pin	Single	Dual
1	+ Vin	+ Vin
11	No pin	Common
12	-Vout	No pin
13	+Vout	-Vout
15	No pin	+Vout
23	- Vin	- Vin
24	- Vin	- Vin

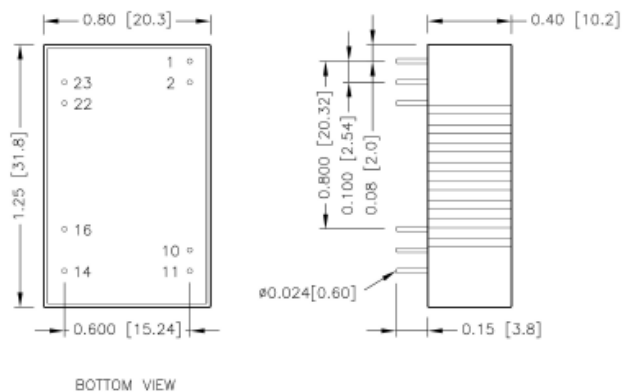
B TYPE

1. All dimensions in inch [mm]
2. Tolerance :x.xx±0.02 [x.x±0.5]
x.xxx±0.01 [x.xx±0.25]
3. Pin dimension tolerance ±0.004[0.10]

Pin Connection

Pin	Single	Dual
1	Ctrl (Option) / No pin*	Ctrl (Option) / No pin*
2	- Vin	- Vin
10	Trim (Option) / No pin*	Trim (Option) / No pin*
11	No pin / NC **	-Vout
14	+Vout	+Vout
16	-Vout	Common
22	+Vin	+Vin
23	+Vin	+Vin

*	If don't choose Ctrl or Trim option, there is no pin on the corresponding pin number.
**	Pin 11 is "No pin" for 43MOP10-□□S□□□ B-T 43MOP10-□□S□□□ B-PT Pin 11 is "NC" for 43MOP10-□□S□□□ B 43MOP10-□□S□□□ B-P

Recommended Pad Layout

A TYPE

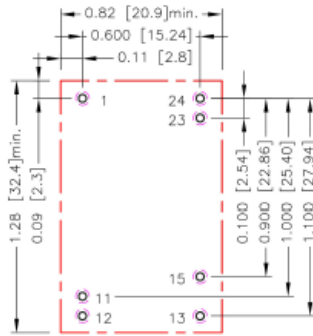

All dimensions in inch[mm]
 Pad size(lead free recommended)
 Through hole 1.11.12.13.15.23.24: $\Phi 0.035[0.90]$
 Top view pad 1.11.12.13.15.23.24: $\Phi 0.044[1.13]$
 Bottom view pad 1.11.12.13.15.23.24: $\Phi 0.071[1.80]$

B TYPE

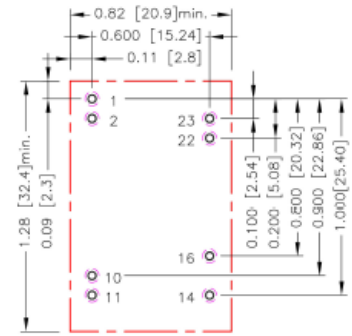

All dimensions in inch[mm]
 Pad size(lead free recommended)
 Through hole 1.2.10.11.14.16.22.23: $\Phi 0.035[0.90]$
 Top view pad 1.2.10.11.14.16.22.23: $\Phi 0.044[1.13]$
 Bottom view pad 1.2.10.11.14.16.22.23: $\Phi 0.071[1.80]$

- * There should be at least 8mm distance between primary and secondary circuit.
- ** For further information, please contact P-DUKE.

Thermal Considerations

The power module operates in a variety of thermal environments. However, sufficient cooling should be provided to help ensure reliable operation of the unit. Heat is removed by conduction, convection, and radiation to the surrounding Environment. Proper cooling can be verified by measuring the point as the figure below. The temperature at this location should not exceed "Maximum case temperature". When operating, adequate cooling must be provided to maintain the test point temperature at or below "Maximum case temperature". You can limit this Temperature to a lower value for extremely high reliability.

- Thermal test condition with vertical direction by natural convection (20LFM).

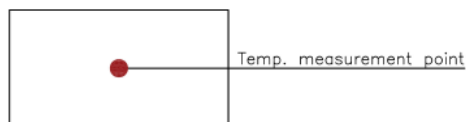

TOP VIEW

Output Voltage Adjustment

It allows the user to increase or decrease the output voltage of the module.

This is accomplished by connecting an external resistor between the Trim pin and either the +Vout or -Vout pins.

With an external resistor between the Trim and -Output pin, the output voltage increases.

With an external resistor between the Trim and +Output pin, the output voltage decreases.

The external Trim resistor needs to be at least 1/16W of rated power.

EXTERNAL OUTPUT TRIMMING

Output can be externally trimmed by using the method shown below.

Trim-up

Trim Up Equation

$$R_U = \left[\frac{G \times L}{(V_{o,up} - L - K)} - H \right] \Omega$$

Trim Down Equation

$$R_D = \left[\frac{(V_{o,down} - L) \times G}{(V_o - V_{o,down})} - H \right] \Omega$$

EXTERNAL OUTPUT TRIMMING

Output can be externally trimmed by using the method shown below

Single Output

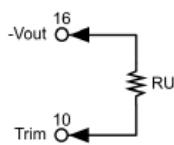

Dual Output

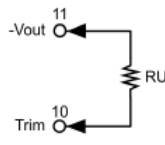

Trim constants

Module	G	H	K	L
□□S3P3B-□T, □□S3P3WB-□T	5110	2050	0.8	2.5
□□S05B-□T, □□S05WB-□T	5110	2050	2.5	2.5
□□S12B-□T, □□S12WB-□T	10000	5110	9.5	2.5
□□S15B-□T, □□S15WB-□T	10000	5110	12.5	2.5
□□S24B-□T, □□S24WB-□T	56000	13000	21.5	2.5

Module	G	H	K	L
□□D05B-□T, □□D05WB-□T	3000	3000	7.5	2.5
□□D12B-□T, □□D12WB-□T	56000	13000	21.5	2.5
□□D15B-□T, □□D15WB-□T	30000	13000	27.5	2.5

□□S3P3B-□T, □□S3P3WB-□T

ΔV (%)	1	2	3	4	5	6	7	8	9	10
Vout (V)	3.333	3.366	3.399	3.432	3.465	3.498	3.531	3.564	3.597	3.630
RU (kΩ)	385.071	191.511	126.990	94.730	75.374	62.470	53.253	46.340	40.963	36.662

□□S05B-□T, □□S05WB-□T

ΔV (%)	1	2	3	4	5	6	7	8	9	10
Vout (V)	5.050	5.100	5.150	5.200	5.250	5.300	5.350	5.400	5.450	5.500
RU (kΩ)	253.450	125.700	83.117	61.825	49.050	40.533	34.450	29.888	26.339	23.500

□□S12B-□T, □□S12WB-□T

ΔV (%)	1	2	3	4	5	6	7	8	9	10
Vout (V)	12.120	12.240	12.360	12.480	12.600	12.720	12.840	12.960	13.080	13.200
RU (kΩ)	203.223	99.057	64.334	46.973	36.557	29.612	24.652	20.932	18.038	15.723

□□S15B-□T, □□S15WB-□T

ΔV (%)	1	2	3	4	5	6	7	8	9	10
Vout (V)	15.150	15.300	15.450	15.600	15.750	15.900	16.050	16.200	16.350	16.500
RU (kΩ)	161.557	78.223	50.446	36.557	28.223	22.668	18.700	15.723	13.409	11.557

Ideal Power Limited

14 Larks Way, Tree Beech Enterprise Park, Gunn, Barnstaple, Devon, England, EX32 7NZ.

www.idealpower.co.uk | +44 (0) 845 260 3400

Trim-up (Continued)
S15B-□T, □□S15WB-□T

ΔV (%)	1	2	3	4	5	6	7	8	9	10
Vout (V)	16.650	16.800	16.950	17.100	17.250	17.400	17.550	17.700	17.850	18.000
RU (kΩ)	10.042	8.779	7.711	6.795	6.001	5.307	4.694	4.149	3.662	3.223

S24B-□T, □□S24WB-□T

ΔV (%)	1	2	3	4	5	6	7	8	9	10
Vout (V)	24.240	24.480	24.720	24.960	25.200	25.440	25.680	25.920	26.160	26.400
RU (kΩ)	570.333	278.667	181.444	132.833	103.667	84.222	70.333	59.917	51.815	45.333

ΔV (%)	11	12	13	14	15	16	17	18	19	20
Vout (V)	26.640	26.880	27.120	27.360	27.600	27.840	28.080	28.320	28.560	28.800
RU (kΩ)	40.030	35.611	31.872	28.667	25.889	23.458	21.314	19.407	17.702	16.167

D05B-□T, □□D05WB-□T

ΔV (%)	11	12	13	14	15	16	17	18	19	20
Vout (V)	±5.050	±5.100	±5.150	±5.200	±5.250	±5.300	±5.350	±5.400	±5.450	±5.500
RU (kΩ)	72.000	34.500	22.000	15.750	12.000	9.500	7.714	6.375	5.333	4.500

D12B-□T, □□D12WB-□T

ΔV (%)	1	2	3	4	5	6	7	8	9	10
Vout (V)	±12.120	±12.240	±12.360	±12.480	±12.600	±12.720	±12.840	±12.960	±13.080	±13.200
RU (kΩ)	570.333	278.667	181.444	132.833	103.667	84.222	70.333	59.917	51.815	45.333

□□D15B-□T, □□D15WB-□T

ΔV (%)	1	2	3	4	5	6	7	8	9	10
Vout (V)	±15.150	±15.300	±15.450	±15.600	±15.750	±15.900	±16.050	±16.200	±16.350	±16.500
RU (kΩ)	237.000	112.000	70.333	49.500	37.000	28.667	22.714	18.250	14.778	12.000

Trim-down

Single & Dual Output

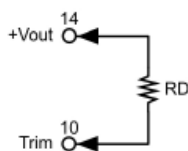
□□S3P3B-□T, □□S3P3WB-□T

ΔV (%)	1	2	3	4	5	6	7	8	9	10
Vout (V)	3.267	3.234	3.201	3.168	3.135	3.102	3.069	3.036	3.003	2.970
RU (kΩ)	116.719	54.779	34.133	23.810	17.616	13.486	10.537	8.325	6.604	5.228

□□S05B-□T, □□S05WB-□T

ΔV (%)	1	2	3	4	5	6	7	8	9	10
Vout (V)	4.950	4.900	4.850	4.800	4.750	4.700	4.650	4.600	4.550	4.500
RU (kΩ)	248.340	120.590	78.007	56.715	43.940	35.423	29.340	24.778	21.229	18.390

□□S12B-□T, □□S12WB-□T

ΔV (%)	1	2	3	4	5	6	7	8	9	10
Vout (V)	11.880	11.760	11.640	11.520	11.400	11.280	11.160	11.040	10.920	10.800
RU (kΩ)	776.557	380.723	248.779	182.807	143.223	116.834	97.985	83.848	72.853	64.057

□□S15B-□T, □□S15WB-□T

ΔV (%)	1	2	3	4	5	6	7	8	9	10
Vout (V)	14.850	14.700	14.550	14.400	14.250	14.100	13.950	13.800	13.650	13.500
RU (kΩ)	818.223	401.557	262.668	193.223	151.557	123.779	103.938	89.057	77.483	68.223

Ideal Power Limited

14 Larks Way, Tree Beech Enterprise Park, Gunn, Barnstaple, Devon, England, EX32 7NZ.

www.idealpower.co.uk | +44 (0) 845 260 3400

Trim-down (Continued)

□□S24B-□T, □□S24WB-□T											
ΔV (%)	1	2	3	4	5	6	7	8	9	10	
Vout (V)	23.760	23.520	23.280	23.040	22.800	22.560	22.320	22.080	21.840	21.600	
RU (kΩ)	4947.667	2439.333	1603.222	1185.167	934.333	767.111	647.667	558.083	488.407	432.667	
□□D05B-□T, □□D05WB-□T											
ΔV (%)	1	2	3	4	5	6	7	8	9	10	
Vout (V)	±4.950	±4.900	±4.850	±4.800	±4.750	±4.700	±4.650	±4.600	±4.550	±4.500	
RU (kΩ)	219.000	106.500	69.000	50.250	39.000	31.500	26.143	22.125	19.000	16.500	
□□D12B-□T, □□D12WB-□T											
ΔV (%)	1	2	3	4	5	6	7	8	9	10	
Vout (V)	±11.880	±11.760	±11.640	±11.520	±11.400	±11.280	±11.160	±11.040	±10.920	±10.800	
RU (kΩ)	4947.667	2439.333	1603.222	1185.167	934.333	767.111	647.667	558.083	488.407	432.667	
□□D15B-□T, □□D15WB-□T											
ΔV (%)	1	2	3	4	5	6	7	8	9	10	
Vout (V)	±14.850	±14.700	±14.550	±14.400	±14.250	±14.100	±13.950	±13.800	±13.650	±13.500	
RU (kΩ)	2707.000	1332.000	873.667	644.500	507.000	415.333	349.857	300.750	262.556	232.000	